

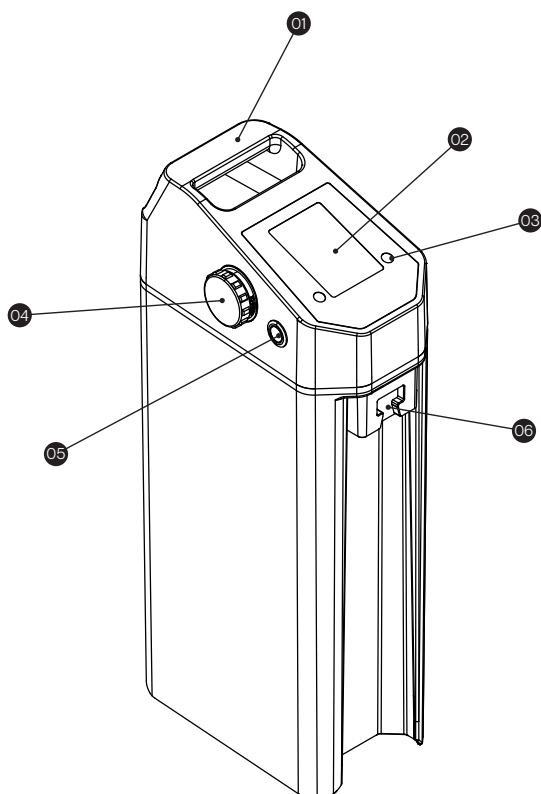

// U 2	BATTERY
USER MANUAL	U2B2603A
U-SERIES ELECTRIC OUTBOARD MOTORS	

ANATOMY



- 01 Battery handle
- 02 Screen
- 03 Display units button
- 04 Charging / Remote connector
- 05 On/Off button
- 06 Battery connector

SPECIFICATIONS

TECHNICAL U-2 BATTERY

CAPACITY	1.4 kWh
VOLTAGE	48 VOLT
CELL TYPE	LI-ION
CYCLE LIFE	1000 cycles to 80% capacity
TRIP COMPUTER	INTEGRATED IN BATTERY WITH SPEED AND RANGE DISPLAY
WEIGHT	8 KG

CERTIFICATIONS

The U-2 battery is certified in accordance with the following standards and relevant parts thereof:

EN IEC 55014
EN61000
IEC62133
EN61000
1542/EU/2023
UL62133/UL2054
FCC
PSE

IMPORTANT SAFETY NOTICE

- Read this manual before use.
- Check that the connectors are fully inserted and the battery is in good condition.
- Battery would not be fully charged for shipping purpose. Please fully charge the battery before first use.
- Do not disassemble the battery.
- Do not use battery when a fault page appears one the screen.
- Store battery in a cool, dry environment.
- **For long term storage, fully charge the battery. Every 6 months, check the battery level and fully charge the battery, if the battery level is below the orange bars. Failure to do so may lead to permanent battery damage.**

