

// U
2**USER MANUAL**

U22603A

U-SERIES ELECTRIC OUTBOARD MOTORS

Congratulations on your purchase of a Momentum electric outboard motor.

We started Momentum to create the best user experience possible in electrified marine propulsion and we are sure you will enjoy using the outboard as much as we have enjoyed creating it.

Please read this manual comprehensively as it contains crucial information on set-up, operation, maintenance and safety. By using this Momentum electric outboard motor, it is deemed that you have read and understood the contents of this user guide and Momentum accepts no liability in the event of misuse of this product.

We reserve the right to update this User Guide in-line with any evolution of this product.

Please visit our website for the latest version of this user guide.



www.momentumelectricmarine.com

CONTENTS

IN THE BOX	3
ANATOMY	4
SPECIFICATIONS	6
CERTIFICATIONS	6
KEY FEATURES	7
INSTALLATION	8
OPERATION	11
PRE-SEA CHECK	16
MAINTENANCE & INSPECTION	17
TROUBLESHOOTING	20
WARRANTY	23
USER NOTES	24

IN THE BOX

U-2 Outboard with propeller

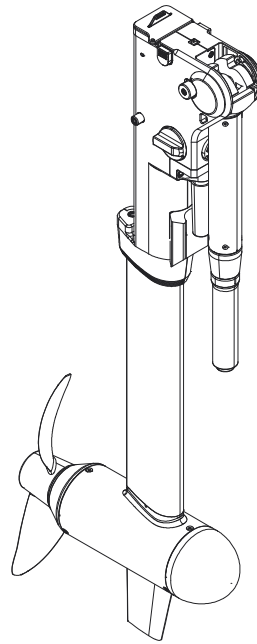

U-series transom mount

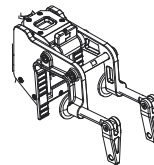

U-2 charger

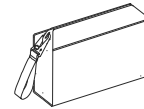

Killswitch X 2

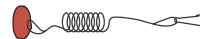

User guide/ Warranty card

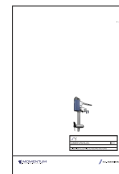

U-2 battery

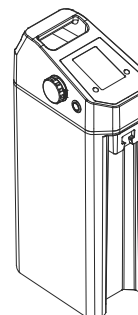

ANATOMY

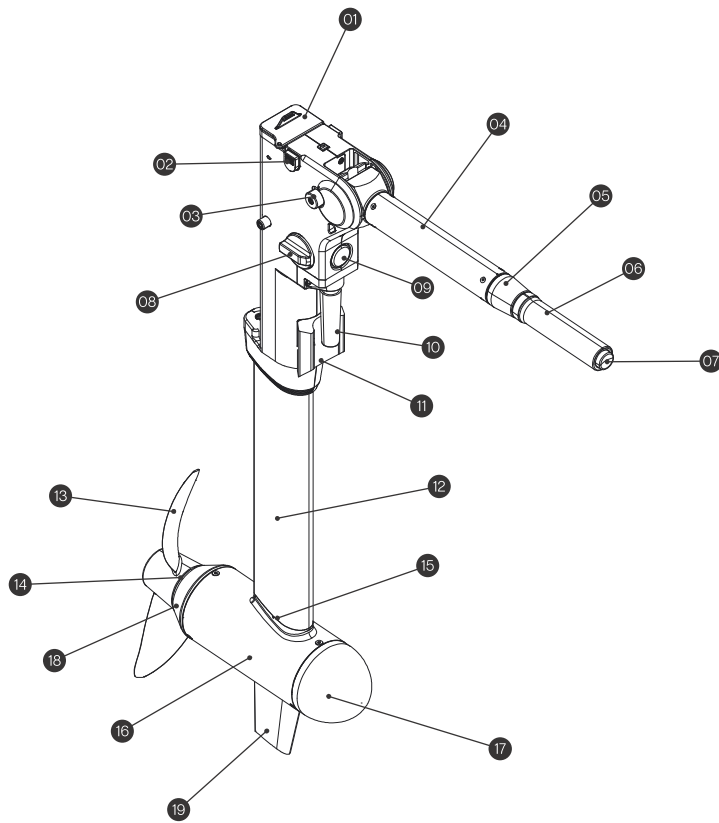

- 01 Battery connector weather cap
- 02 Battery release button
- 03 Tiller release knob
- 04 Tiller body
- 05 Throttle friction adjuster
- 06 Throttle grip
- 07 Safety button
- 08 Steering lock
- 09 Killswitch attachment point
- 10 Steering shaft
- 11 Steering end stop block
- 12 Stem
- 13 Propeller
- 14 Motor anode
- 15 Stem drain holes
- 16 Motor case
- 17 ESC endcap
- 18 Propeller endcap
- 19 Anti-grounding skeg

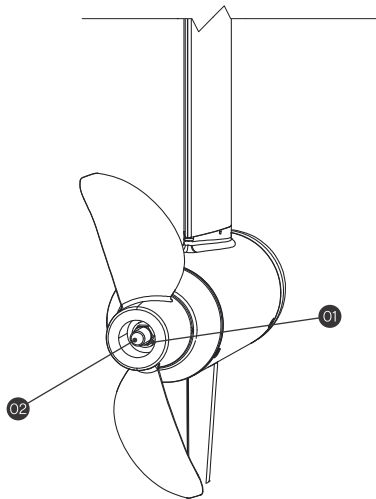

- 01 Propeller nut
- 02 Propeller anode

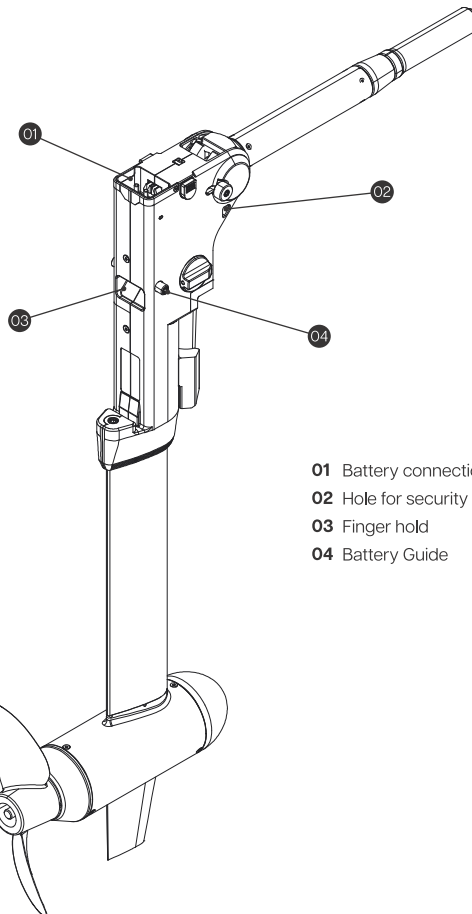

- 01 Battery connection
- 02 Hole for security wire/ Safety line
- 03 Finger hold
- 04 Battery Guide

ANATOMY U-2 ELECTRIC OUTBOARD MOTOR

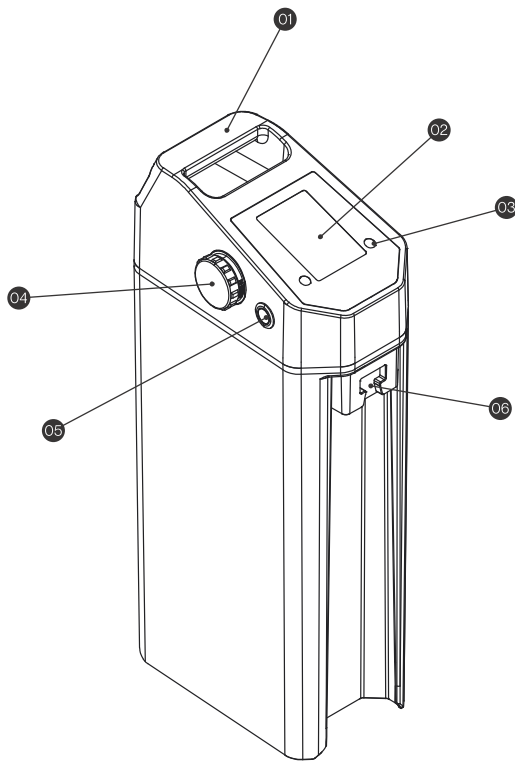

- 01 Battery handle
- 02 Screen
- 03 Display units button
- 04 Charging / Remote connector
- 05 On/Off button
- 06 Battery connector

ANATOMY U-2 BATTERY

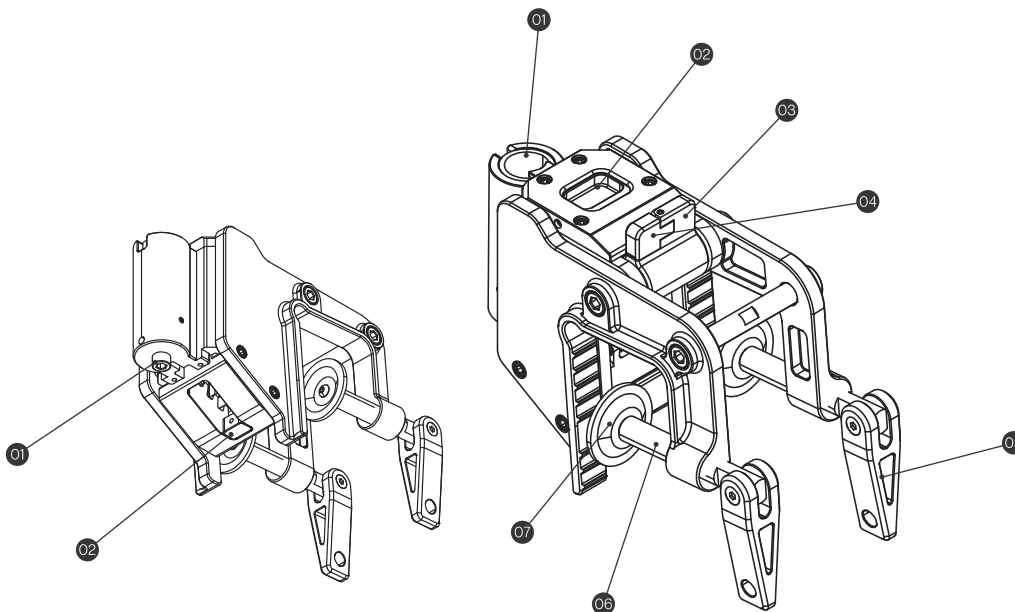

- 01 Steering liner
- 02 Locking latch
- 03 Trim/tilt lever
- 04 Kickup trim lever
- 05 Clamp handle
- 06 Clamp threaded rod
- 07 Clamp cup

- 01 Steering friction adjustment screw
- 02 Transom mount anode

ANATOMY U-SERIES MOUNT

SPECIFICATIONS

TECHNICAL U-2 ELECTRIC OUTBOARD MOTOR

MAX INPUT POWER	2.5 kW
SHAFT LENGTH	39CM SHORT / 52CM LONG
PROP. DIAMETER	25 CM
NO. OF BLADES	2
COOLING SYSTEM	100% EXTERNAL PASSIVE SEAWATER
WEIGHT	9 KG

TECHNICAL U-2 BATTERY

CAPACITY	1.4 kWh
VOLTAGE	48 VOLT
CELL TYPE	LI-ION
CYCLE LIFE	1000 cycles to 80% capacity
TRIP COMPUTER	INTEGRATED IN BATTERY WITH SPEED AND RANGE DISPLAY
WEIGHT	8 KG

CERTIFICATIONS

The U-2 OBM is certified in accordance with the following standards and relevant parts thereof:

EN IEC 55014
EN IEC 61000
FCC
PSE
RoHS

The U-2 battery is certified in accordance with the following standards and relevant parts thereof:

EN IEC 55014
EN61000
IEC62133
EN61000
1542/EU/2023
UL62133/UL2054
FCC
PSE

KEY FEATURES

OBM

- Designed for ultimate portability and simple one-man installation.
- As the lightest OBM in its class, the U-2 is the only 2.5kW OBM designed with no exposed cables and a multi-function foldaway tiller, capable of sustained 2.5kW continuous power output at full throttle.

Cable Free Design

- Simply plug and play. Robustly built power and data pins are individually sealed when the battery slots into the outboard unit – delivering a fully waterproof IP67 connection with zero exposed cables.

Quick Mount and Dismount

- The quick-release mounting clamp system enables single-person installation and removal in seconds, while providing rock-solid security during operation – the fastest mount-dismount process in its class.

Compact, Feature-Rich Design

- Engineered to pack an exceptional number of features into a compact package, making life on the water as effortless as possible – no pins to fumble with. Just click and go.
- Removing the OBM from the transom is as simple as releasing the locking latch and pulling the unit free.
- Trim the OBM with a single click of the trim lever – no loose locking pins at risk of dropping overboard.
- A kickup trim lever lets the OBM kick-up freely on contact with the beach or any underwater obstacle.

Multiple-Position Folding tiller

- Three operating positions designed for every situation: (1) fully folded for storage and transport, (2) standard for normal operations, and (3) fully extended for standing operation – always providing optimal control and reach.
- Integrated steering lock knob keeps the motor firmly in position during transport or when steering with an external rudder, eliminating the frustration of traditional pin-based systems.

GPS-Enabled Trip Computer

- With a screen optimised for outdoor use, the trip computer displays everything you need at a glance – boat speed, remaining battery capacity, power levels, and range or time remaining. Simple, functional, and built for life at sea.

INSTALLATION

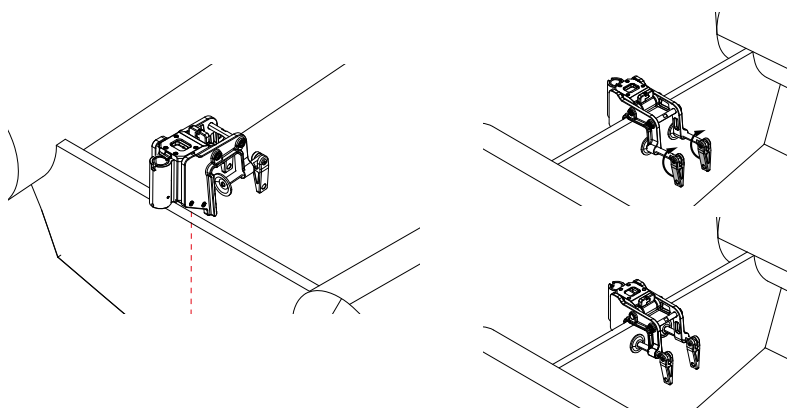

Dia. 1.A

INSTALLING THE MOUNT

- 1.1. Install the mount dead-centre to the transom of your boat as shown in the diagram to the left and secure the mount clamps to the transom with hand tightness. **(Dia 1.A)**

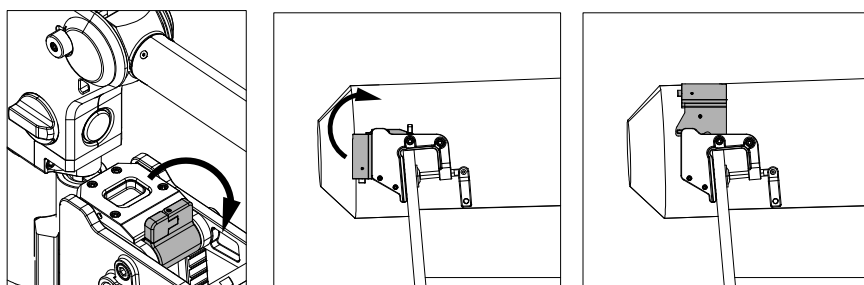

Dia. 2.A

INSTALLING THE OUTBOARD MOTOR

- 2.1. Keep hands and fingers clear of moving parts when tilting the mount. Pull the trim lever to tilt the mount to the highest position to receive the outboard. Release the trim lever and ensure that it clicks into place. **(Dia 2.A)**
- 2.2. Pull the tiller lock knob and unfold it 180 degrees as shown in the diagram. **(Dia 2.B)**
- 2.3. Check that the locking latch is in the locked position. **(Dia 2.C)**

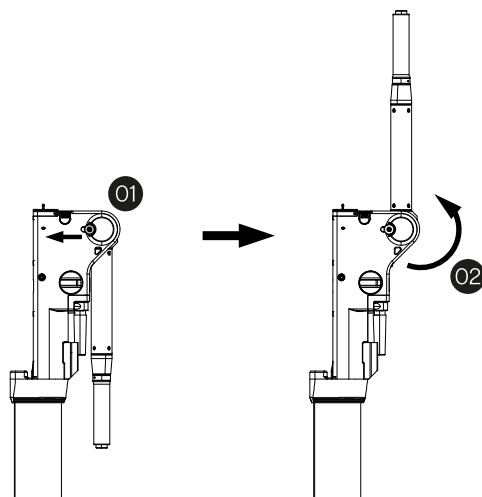

Dia. 2.B

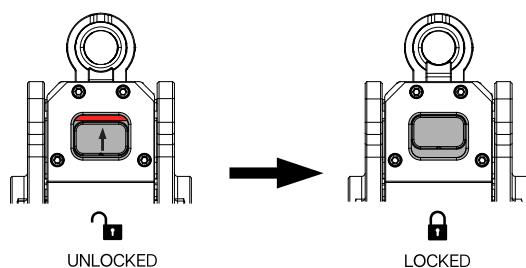

Dia. 2.C

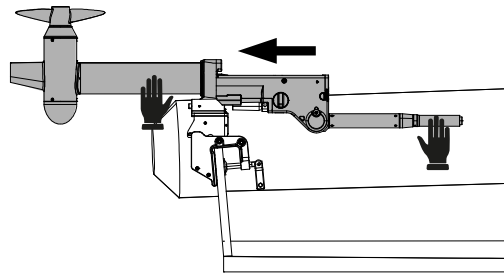

Dia. 2.D

- 2.4. Slide the steering shaft of the obm into the steering liner of the transom mount until there is a click. **(Dia 2.D)**
- 2.5. Turn the OBM such that the propeller shaft is pointing up and engage the steering lock. **(Dia 2.E)**

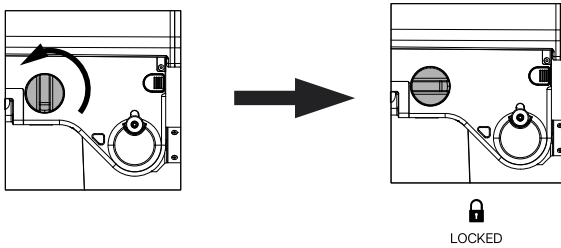

Dia. 2.E

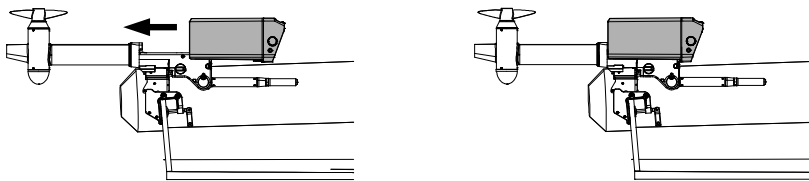

Dia. 3.A

INSTALLING THE BATTERY

- 3.1. Slide the battery over the battery guides. **(Dia 3.A)**
- 3.2. Push the battery to engage the obm connectors until the battery release buttons click and pop out
- 3.3. Pull the trim/tilt lever and lower the OBM into the water. **(Dia 3.B)**
- 3.4. Unlock the steering lock. **(Dia 3.C)**

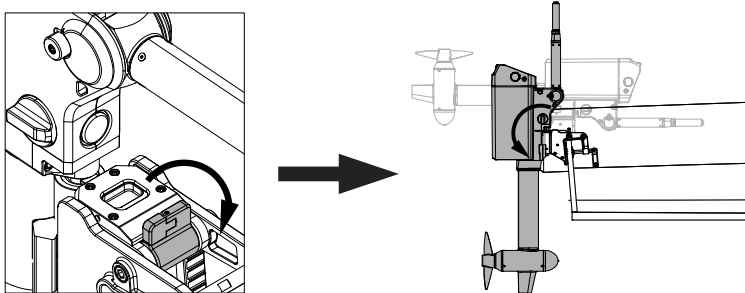

Dia. 3.B

Important! - Check the outboard is locked onto the mount

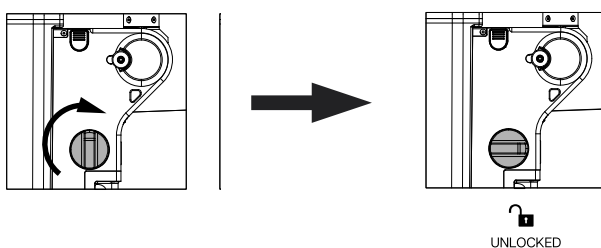

Dia. 3.C

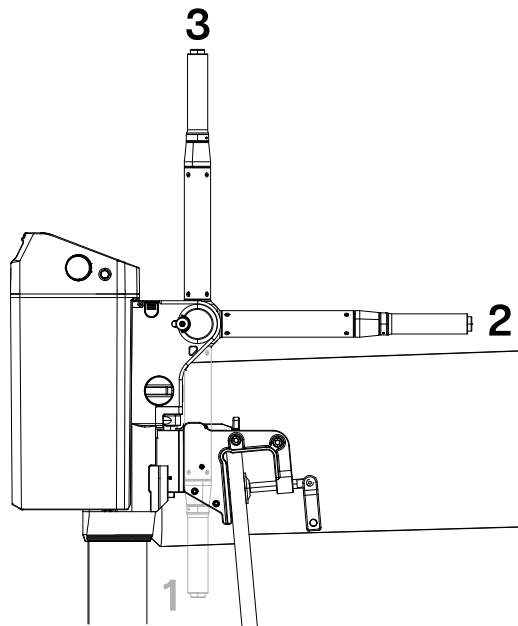

Dia. 4.A

DEPLOYING THE IN-BUILT TILLER

4.1. The tiller has 3 different positions:
(Dia 4.A)

- Position 1 - Storage
- Position 2 - Normal
- Position 3 - Installation / Extended

- 4.2. Pull or push the tiller lock knob to unlock the tiller and adjust to the desired position from position 1 to 3. The tiller locks at 2 different positions when the OBM is installed.
- 4.3. Switch between Position 2 and Position 3 depending on your needs.
- 4.4. Position 2 will be more suited to operations while sitting whereas an intermediate position between Positions 2 and 3 is suitable when standing.
- 4.5. Check that the OBM can be turned from starboard to port without any obstruction.

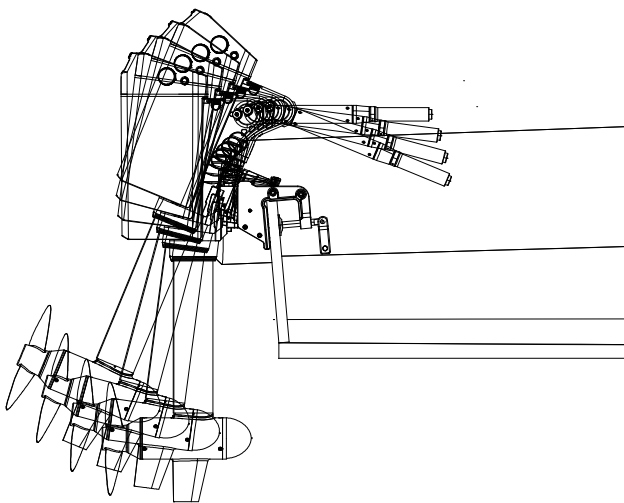

Dia. 5.A

TRIM ANGLE ADJUSTMENT

- 5.1. Stop the boat before making any trim adjustments to ensure safe handling
- 5.2. The outboard should be adjusted to one of the 4 different trim positions (**0, 7.5, 15, 22.5 and 90deg**) to suit the boat and running conditions, e.g. number of people in the boat, sea condition, boat type etc. **(Dia 5.A)**
- 5.3. To trim the outboard, pull the trim lever, then pull the tiller to rotate the outboard.
- 5.4. Release the trim lever and ensure that it clicks into place in one of the 4 trim positions.

OPERATION

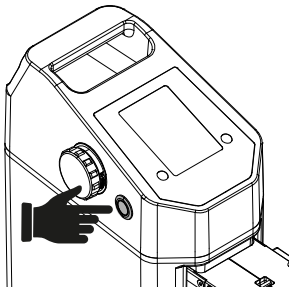

Dia. 6.A



READY

POWERING THE SYSTEM

- 6.1. Always set the throttle to zero before powering the system.
- 6.2. Check that safety button can be depressed and springs back when released.
- 6.3. Press the on/off button on the battery until the trip computer turns on. Once initialised, it will show the READY screen. **(Dia 6.A)**
- 6.4. If the ZERO THROTTLE screen is shown, perform the following steps to zero the throttle.

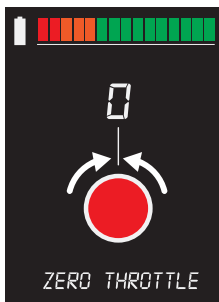

Dia. 7.A

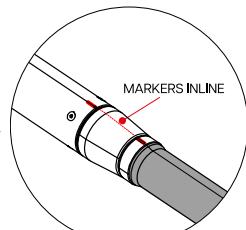

THROTTLE AT ZERO



READY

SETTING THE THROTTLE TO ZERO

- 7.1. Loosen the throttle friction lock until the throttle springs back to zero. The return should happen automatically and the markers on the throttle will be aligned. **(Dia 7.A)**

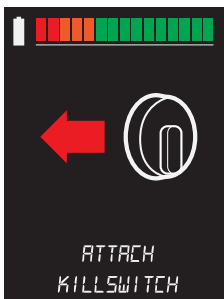

Dia. 8.A

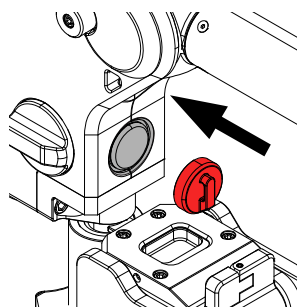

ATTACHING THE KILLSWITCH

- 8.1. Secure the killswitch leash to your wrist or life jacket.
- 8.2. Once ready to make way, attach the killswitch to the red ring on the OBM front. The killswitch is designed to be pressed onto and over the red ring. **(Dia 8.A)**
- 8.3. The screen will switch from the READY screen to the LIVE screen.

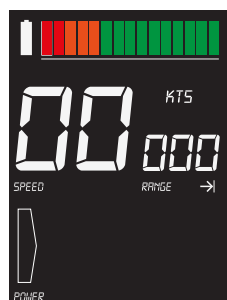

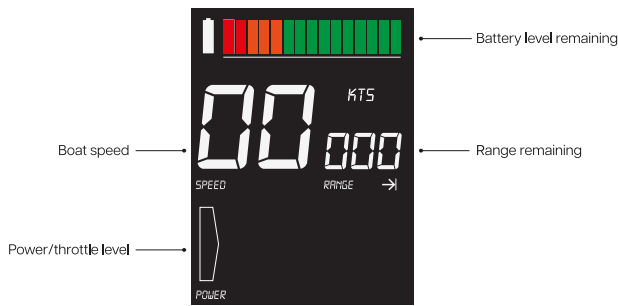

Dia. 9.A

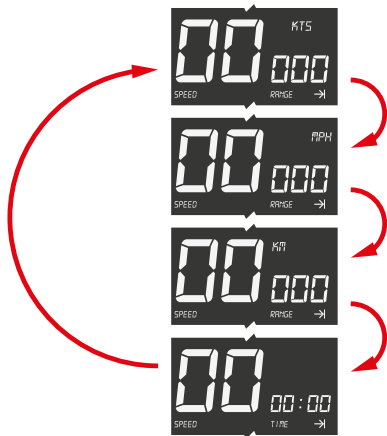
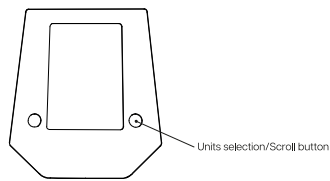

Dia. 9.B

YOUR OUTBOARD MOTOR SCREEN

- 9.1. The display screen is grouped into 4 parts: **-Battery level remaining, Boat speed, Range remaining, Power/throttle level (Dia 9.A)**
- 9.2. The units for the boat speed and range remaining can be changed by tapping the bottom right button (KM/KTS/MPH). **(Dia 9.B)**

USING THE THROTTLE

- 10.1. The throttle can be freely rotated forward until half throttle.
- 10.2. In order to rotate further forward, the safety button has to be depressed to allow rotation to full throttle.
- 10.3. To rotate the throttle in reverse, first depress the safety button.
- 10.4. The safety button prevents accidental full-power forward and reverse engagement.

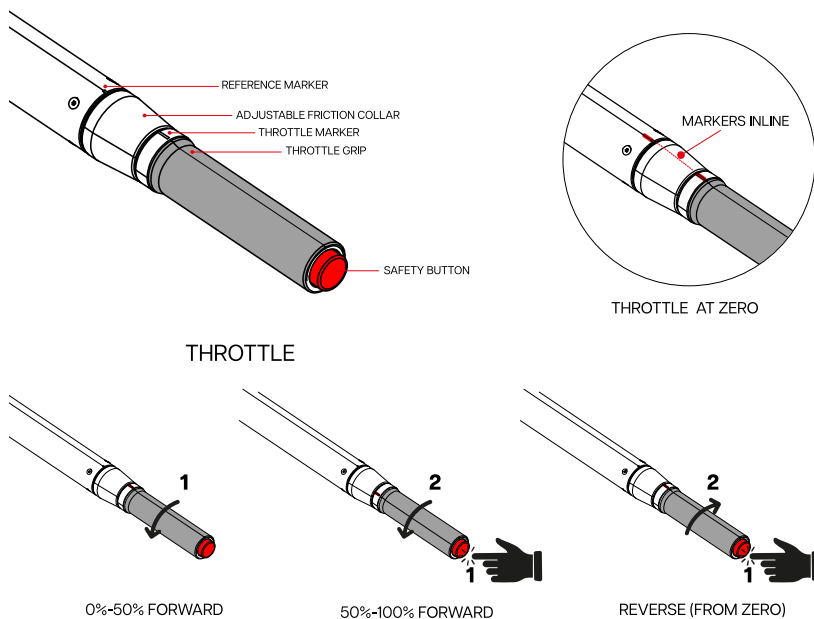

Dia. 10.A

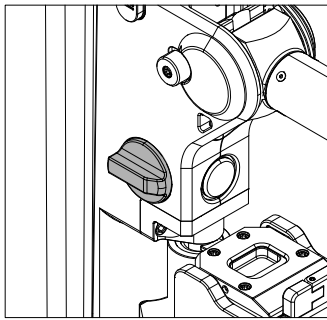

UNLOCKED

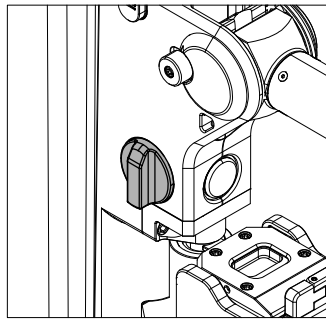

LOCKED

Dia. 11.A

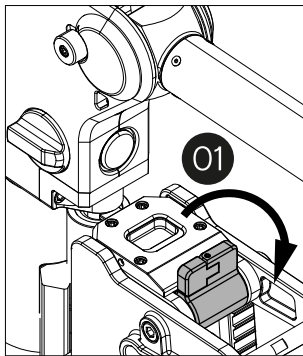

Dia. 12.A

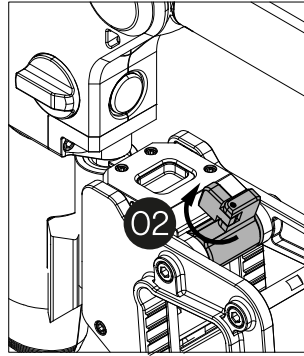

LOCKING STEERING IN PLACE

- 11.1. The steering lock allows the outboard to be locked in place. This is useful when installing or removing the battery from the boat, or when you have a rudder on the boat and just want to use the outboard for propulsion.
- 11.2. **Turn the outboard to face directly centre.**
- 11.3. Turn the steering lock knob to the vertical position to lock the steering in place. **(Dia 11.A)**
- 11.4. To unlock, turn the steering lock back to the horizontal position and the outboard will be free to turn again.

KICKUP TRIM FOR SHALLOW WATERS

- 12.1. On the trim/tilt lever, you can slide the kickup trim lever on to allow the outboard to freely tilt.
- 12.2. This is useful in shallow waters or when you are navigating in waters with possible underwater obstacles.
- 12.3. Pull on the trim/tilt lever and pull the outboard slightly using the tiller. Rotate the free trim lever to the centre position to allow the outboard to freely trim. This will allow the outboard to adjust its position if it strikes an object or touches the ground. **(Dia 12.A)**
- 12.4. To lock back into a trim position, rotate the kickup trim lever back into the horizontal position. The outboard will automatically move into the next lowest trim position. Adjust the trim again as necessary.

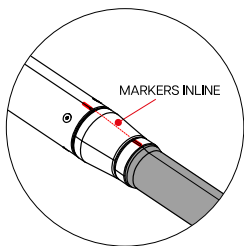

THROTTLE AT ZERO

Dia. 13.A

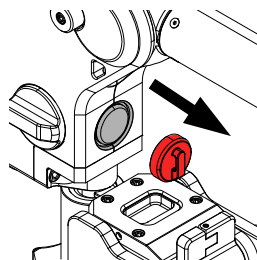

Dia. 13.B

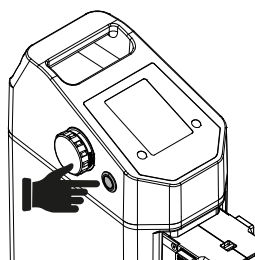

Dia. 13.C

TURNING OFF THE OUTBOARD

- 13.1. Return throttle to zero/neutral position. **(Dia 13.A)**
- 13.2. Remove kill switch. **(Dia 13.B)**
- 13.3. Press power button on battery until the display turns off. **(Dia 13.C)**

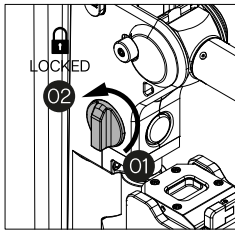

Dia. 14.A

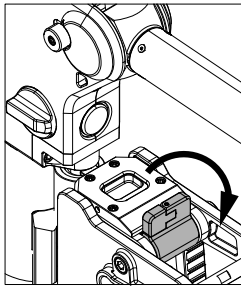

Dia. 14.B

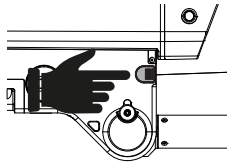

Dia. 14.C

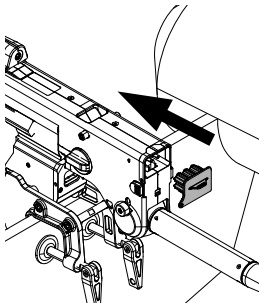
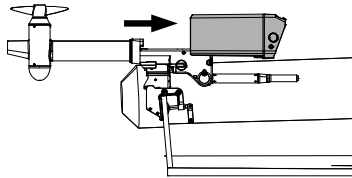
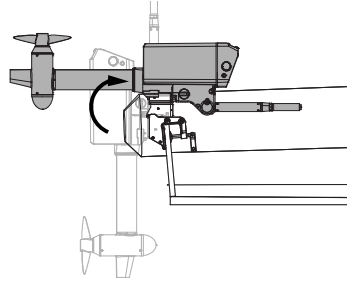

Dia. 14.D

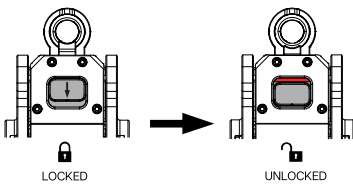

Dia. 15.A

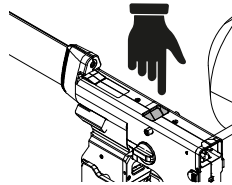

Dia. 15.B

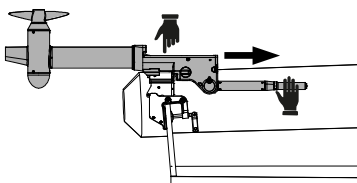

Dia. 15.C

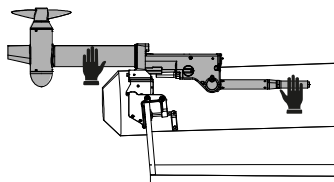

REMOVING THE BATTERY

- 14.1. Lock the steering. **(Dia 14.A)**
- 14.2. Pull the trim lever to raise the obm to the highest position. **(Dia 14.B)**
- 14.3. Press the battery release button on BOTH sides, and pull on handle to remove the battery. **(Dia 14.C)**
- 14.4. Replace the male connector weather cover over the OBM connector. **(Dia 14.D)**

REMOVING THE OUTBOARD

- 15.1. Release the Locking Latch. **(Dia 15.A)**
- 15.2. Use the finger hold to pull the OBM slightly towards the front of the boat to disengage from the steering liner. **(Dia 15.B)**
- 15.3. Use both hands to remove the OBM from the transom mount, supporting the weight towards the motor end. **(Dia 15.C)**

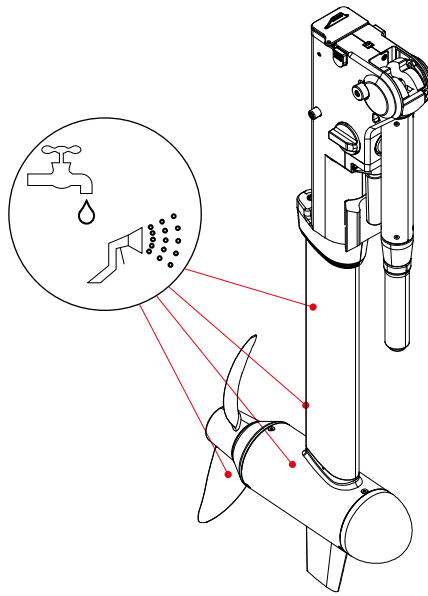

Dia. 16.A

AFTER USING THE OBM

OBM

- 16.1. Rinse down the OBM with fresh water. This is to minimise marine fouling due to extended immersion in fresh or sea water. Allow to dry before storage or transportation. **(Dia 16.A)**
- 16.2. Fold the tiller downwards until it locks into place.

BATTERY

- 16.3. Wipe battery with a dry clean cloth before charging or storage.

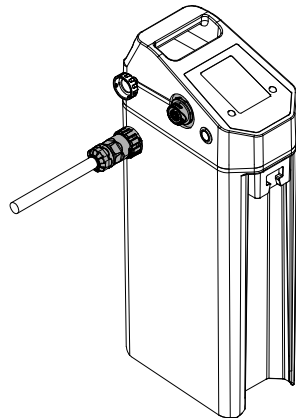

Dia. 17.A

CHARGING & STORAGE

! Charging the battery - connect the charger to the battery BEFORE turning on the charger !

Do not connect the charger to a wet battery.

- 17.1. Store the battery and OBM under dry shelter and within an optimal temperature range of 15°-30°C.
- 17.2. If storing the battery for more than 3 months, always store the battery fully charged and do not let the state of charge drop below 50%..

PRE-SEA CHECK



- [] Throttle can rotate freely and springs return to zero, Safety button can be pressed and released freely.
- [] Tiller is free to rotate and can be locked in position.
- [] Steering is unobstructed and not loose.
- [] Propeller not damaged and securely fastened to OBM with nut and anode.
- [] Transom mount securely seated on transom, both clamps are securely fastened and trim/tilt levers can be pressed and released freely.
- [] OBM and Battery Power/Data connectors are dry before connection.
- [] Kill switch secured to provided leash.
- [] Note the following high risk situations:

Situation	Risk	Solution
Operating in shallow or rocky waters	OBM may strike the seabed or underwater objects	Trim OBM up and proceed at a slow speed or engage the kickup trim feature
Beaching	OBM may strike the seabed or underwater objects	Trim OBM up and proceed at a slow speed or engage the kickup trim feature
Low battery level	Insufficient battery capacity to return	Operate at a lower speed to maximise range

MAINTENANCE & INSPECTION

MAINTENANCE SCHEDULE

Maintenance Task	Maintenance Action	Maintenance Interval
Inspect propeller nut for looseness	Tighten nut	Before each use
Inspect propeller blades and hub for damage	Replace damaged propeller	Before each use
Inspect battery case for damage	Replace damaged battery	Before each use
Inspect connectors for corrosion	Replace damaged connectors	Before each use
Inspect three anodes (propeller, motor, transom mount)	Replace anodes if required	Every 3 months
Grease transom mount	Apply marine grease to clamp	Every 3 months
Inspect transom mount and OBM for loose screws	Tighten loose screws with suitable thread lock / anti-corrosive compound	Every 6 months
Inspect transom mount for cracks	Replace damaged parts	Every 6 months
Recommended yearly inspection	Bring OBM to dealer for recommended yearly inspection (seals, O-rings, connectors)	Every 12 months

REPLACEMENT PROCEDURES

Tools & parts required

18.1. Standard metric hand tools and electrical equipment are required for the tasks. :

- allen key wrench set
- socket wrench set
- needle nose pliers

18.2. Consumables required are:

- Tefgel anti-corrosion/anti-seize
- Loctite 243
- Loctite 425 (suitable for use with plastics)
- marine grease

PROPELLER

Propeller and Propeller Anode removal [Dia 19.A]

- 19.1. Remove the nylon lock nut.
- 19.2. Remove the propeller anode.
- 19.3. Remove the propeller, taking care that the shaft pin remains in place through the shaft.

Propeller and Propeller Anode installation

- 19.4. Ensure that the shaft pin is balanced through the shaft.
- 19.5. Install the new propeller onto the shaft, taking care to align the slot on the propeller with the shaft pin.
- 19.6. Fit the new propeller anode onto the shaft.
- 19.7. Fit on and tighten the nylon lock nut onto the shaft.

Motor Anode removal [Dia 19.B]

- 19.8. Remove the propeller and propeller anode.
- 19.9. Remove the two securing screws.
- 19.10. Remove the motor anode. Should the anode be difficult to remove by hand, use a flat screwdriver and a small mallet to lightly tap the motor anode to loosen it, before removing it by hand.

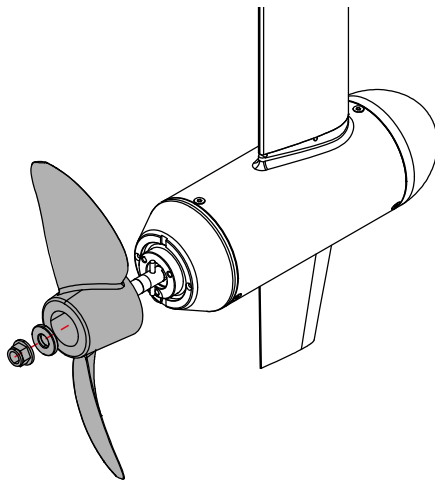

Dia. 19.A

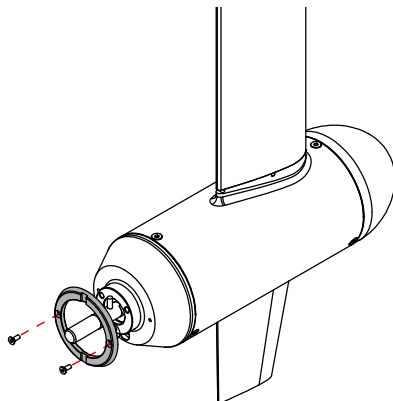

Dia. 19.B

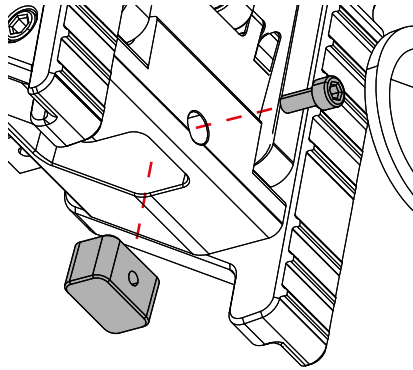

Dia. 19.C

Motor anode installation

- 19.11. Apply some Tefgel or suitable marine anti-corrosive/anti-sieze compound to the screw threads.
- 19.12. Fit on the motor anode.
- 19.13. Fit and tighten the screws.
- 19.14. Install the propeller and propeller anode.

Transom anode removal [Dia 19.C]

- 19.15. Remove the screw.
- 19.16. Remove the anode.

Transom anode installation

- 19.17. Apply some Tefgel or suitable marine anti-corrosive/anti-sieze compound to the screw threads.
- 19.18. Fit on the anode.
- 19.19. Fit and tighten the screw.

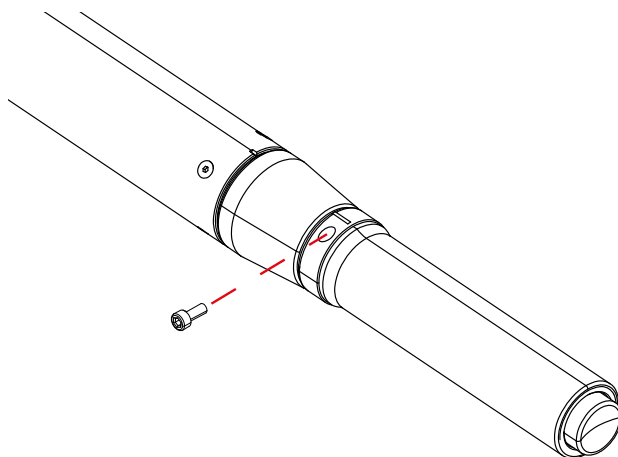

Dia. 20.A

THROTTLE GRIP





- 20.3. Loosen screw and slide grip off throttle.
- 20.4. Slide new grip onto throttle.
- 20.5. Align zero throttle marks.
- 20.6. Tighten screw to ensure grip does not slip over throttle.

TROUBLESHOOTING

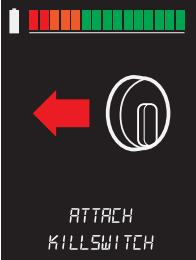
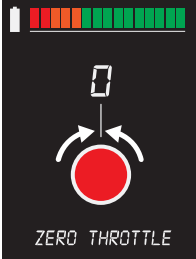
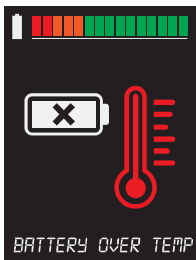
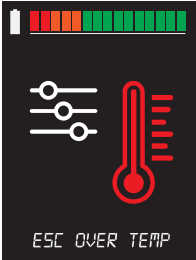
A fault/warning message(s) will appear on the display in the event of an outboard/battery fault or warning.

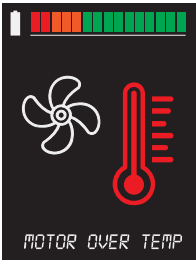
Return the throttle to zero and remove the killswitch before referring to the following table for details and solutions. The outboard will shut down when the temperature of the motor or battery exceeds the limits or the battery voltage drops too low during operation.

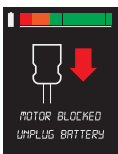
Warning / Fault Message	Likely Cause	Solution
	<p>Killswitch is not placed on tiller or remote throttle</p>	<ul style="list-style-type: none"> • Attach killswitch on tiller or remote throttle
	<p>Throttle has been turned to or held in forward/ reverse direction</p>	<ul style="list-style-type: none"> • Take hand off throttle or loosen throttle friction ring
	<p>Battery cells or BMS temperature has exceeded limit</p>	<ul style="list-style-type: none"> • Stop use of battery • Inspect for physical damage or deformation • Ensure that battery is in a well-ventilated area and ambient temperatures are between the recommended values • Contact your dealer for support
	<p>Electronic Speed Controller (ESC) temperature has exceeded limit</p>	<ul style="list-style-type: none"> • Stop use of motor • Ensure that front end of the motor is free from obstruction and fully immersed in the water • Wait for message to disappear after ESC has cooled down • If message reappears after resuming operation, contact your dealer

	<p>Motor temperature has exceeded limit</p>	<ul style="list-style-type: none"> • Stop use of motor • Ensure that mid-section of the motor is free from obstruction and fully immersed in the water • Check that boat is not overloaded or underpowered • Wait for message to disappear after motor has cooled down • If message reappears after resuming operation, contact your dealer
  	<p>Motor torque demand has exceeded limit</p>	<ul style="list-style-type: none"> • Ensure that outboard is safe to handle • Remove killswitch • Turn off the battery, then disconnect battery from outboard motor • Raise outboard to maximum angle • Inspect propeller and shaft for entanglement with rope/ fishing net/sea weed/etc. • Check that propeller can be rotated freely by hand before resuming operation
	<p>Battery fault, excluding high temperature</p>	<ul style="list-style-type: none"> • Stop use of battery • Inspect for physical damage or deformation • Contact your dealer for support
	<p>Battery level < 20%</p>	<ul style="list-style-type: none"> • Review voyage plan and return to home or operate at reduced speed in a safe manner

OPERATING FAULT TABLE

Description of Observation	Likely Cause	Solution
Propeller sucks air from the water surface (ventilation)	OBM is trimmed up too much / OBM shaft length is not long enough	Trim OBM down
Tiller pulls to one side more than the other	OBM is trimmed down too much	Trim OBM up
Excessive vibrations	Entanglement with seaweed/plastic bag etc. Loose or damaged propeller Loose transom mount	Stop the boat in a safe location, put the throttle to zero, remove the kill switch and tilt the OBM up to check the propeller/transom mount. Take necessary remedial action
No GPS speed display	GPS unit requires more time to acquire satellite fix	Wait for up to 5 minutes from first power on before moving off / more time may be required if boat is moving
OBM display does not light up	Connector is not engaged fully	Check that battery is fully pushed in.
No throttle response	Kill switch is not on Throttle not at zero on first power on	Zero throttle then put on kill switch
Display does not light up	Battery power button not depressed long enough	Press battery power button for about 5 seconds
Display/Battery cannot be turned off	Battery power button not depressed long enough	Press battery power button for about 10 seconds

WARRANTY

The limited warranty of the U-Series outboard motor covers 1 year (commercial use) and 2 years (private use) from the date of delivery.

USER NOTES

