



// M
10

M - SERIES ELECTRIC OUTBOARD MOTORS

USER MANUAL

VER 2501

Congratulations on your purchase of a Momentum electric outboard motor.

We started Momentum to create the best user experience possible in electrified marine propulsion and we are sure you will enjoy using the outboard as much as we have enjoyed creating it.

Please read this manual comprehensively as it contains crucial information on set-up, operation, maintenance and safety. By using this Momentum electric outboard motor, it is deemed that you have read and understood the contents of this user guide and Momentum accepts no liability in the event of misuse of this product.

We reserve the right to update this User Guide in-line with any evolution of this product.

Please visit our website for the latest version of this user guide.

www.momentumelectricmarine.com

CONTENTS

IN THE BOX	3
ANATOMY	4
SPECIFICATIONS	6
CERTIFICATIONS	7
KEY FEATURES	8
INSTALLATION	9
OPERATION	11
PRE-SEA CHECK	15
MAINTENANCE & INSPECTION	16
TROUBLESHOOTING	20
WARRANTY	23
USER NOTES	24

IN THE BOX

Outboard with Propeller

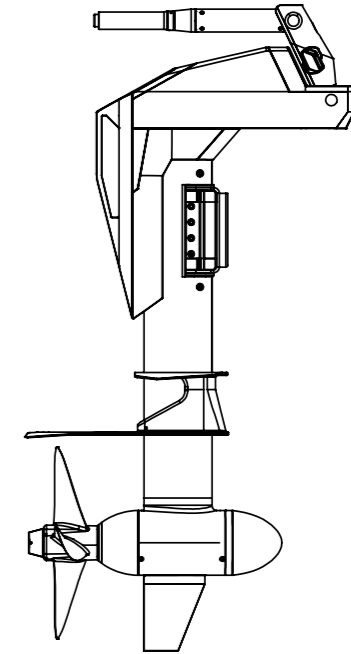

3M Power/Data Cable



OBM End Cable Clamp

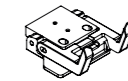

M-series Mount

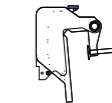

Charger

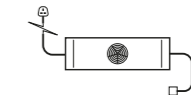

Killswitch

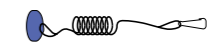

Prop Tool

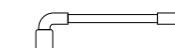

User Guide/ Warranty Card



ANATOMY

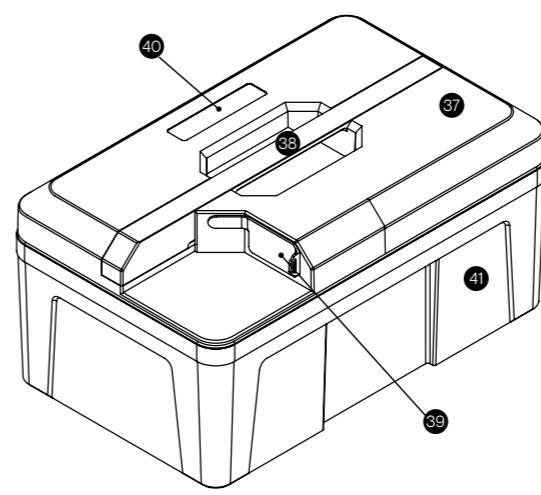
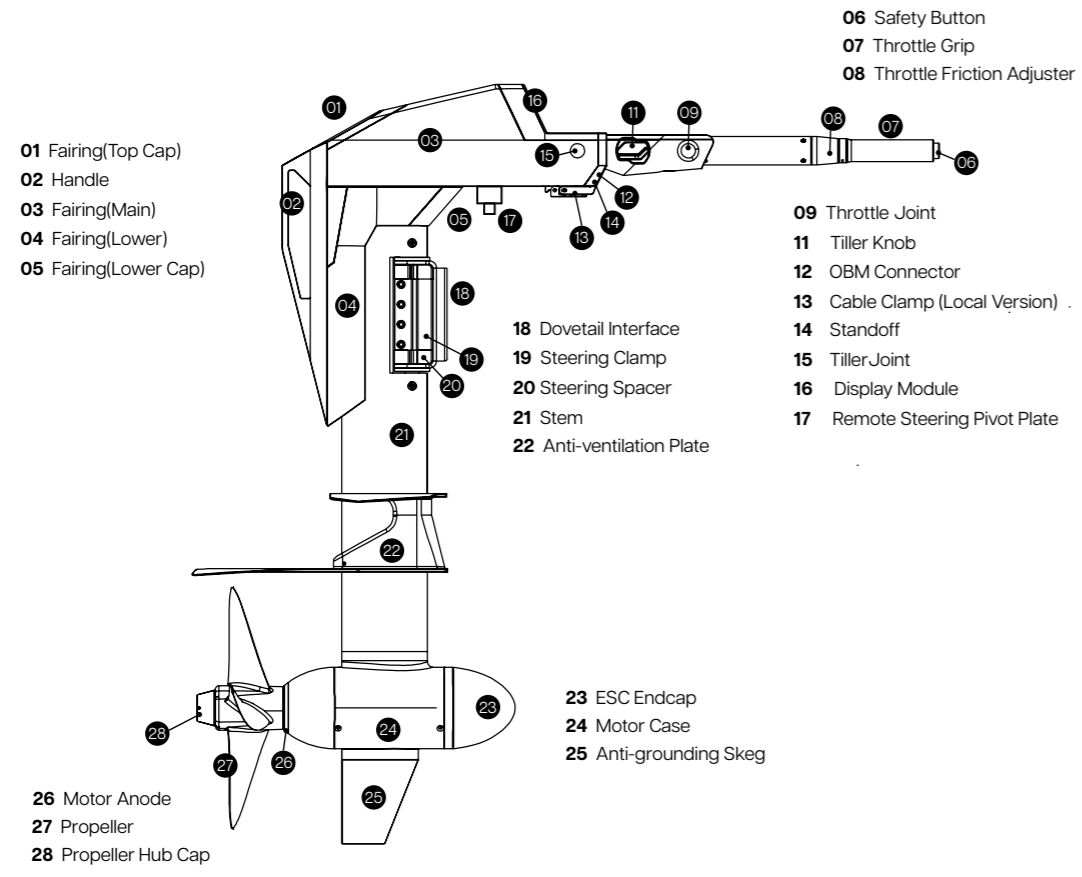

ANATOMY M-10 ELECTRIC OUTBOARD MOTOR

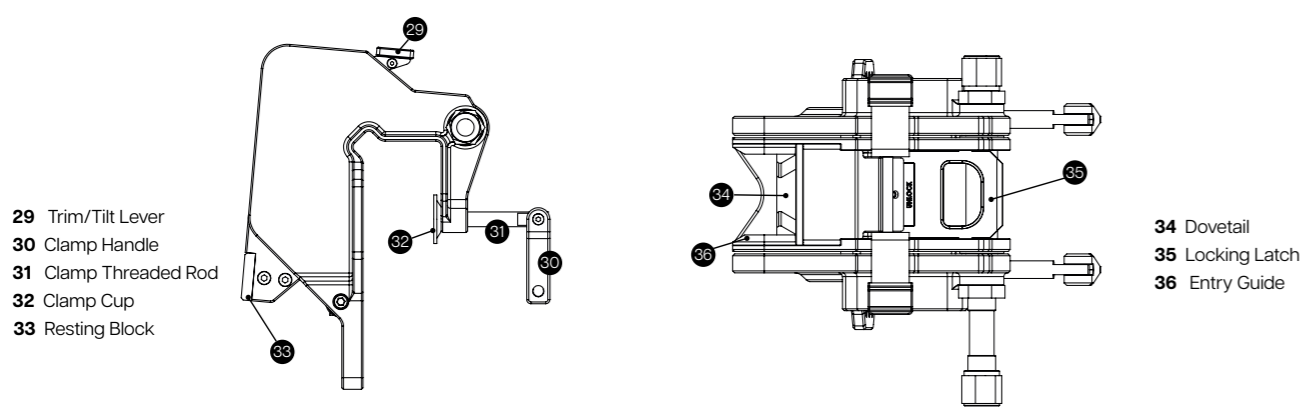

ANATOMY M-B6 BATTERY

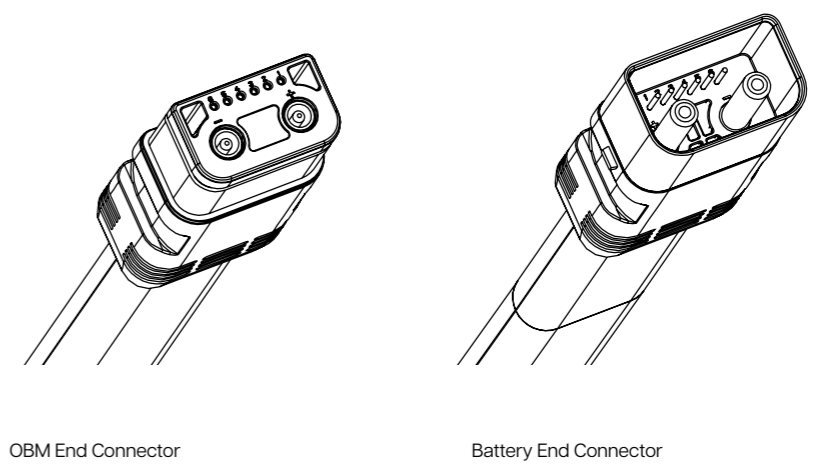

ANATOMY M-SERIES MOUNT

ANATOMY M-SERIES POWER/DATA CABLE

SPECIFICATIONS

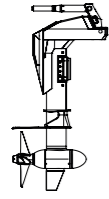

TECHNICAL M-10 ELECTRIC OUTBOARD MOTOR

MAX INPUT POWER	10 kW
SHAFT LENGTH	39CM SHORT / 52CM LONG
PROP. DIAMETER	34CM
NO. OF BLADES	4
COOLING SYSTEM	100% EXTERNAL PASSIVE SEAWATER
TRIP COMPUTER	INTEGRATED GPS POWER AND RANGE DISPLAY
WEIGHT	OBM : 21 KG / MOUNT : 7KG
OBM DIMENSIONS	(CM) 106 X 58 X 21 (SHORT) / 119 X 58 X 21 (LONG)
PACKAGE DIMENSIONS	(CM) 135 x 68 x 31

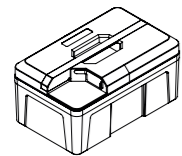

TECHNICAL MB-6 BATTERY

CAPACITY	6.4 kW h
VOLTAGE	72 VOLT
CELL TYPE	LI-ION NMC prismatic
CYCLE LIFE	>1500 cycles to 80% capacity
WEIGHT	37 KG
BATTERY DIMENSIONS	(CM) 47 x 23 x 29
PACKAGE DIMENSIONS	(CM) 56 x 36 x 31

CERTIFICATIONS

TKO TECHNOLOGIES PTE. LTD.
110 Lor 23 Geylang #02-01 Singapore 388410
UEN: 202206220W

EU DECLARATION OF CONFORMITY

Products: M10, M6, MB-6

This declaration of conformity is issued under the sole responsibility of the manufacturer.

The objects of the declaration are in conformity with the following directives and harmonised standards:

Directives	Harmonised Standards
Electromagnetic Compatibility (EMC) 2014/30/EU	EN IEC 55014-1:2021 EN IEC 55014-2:2021 EN IEC 61000-3-2:2019+A2:2024 EN 61000-3-3:2013+A2:2021+AC:2022-01
Low Voltage (LV) 2014/35/EU	EN IEC 62368-1:2020+A11:2020
RoHS 2011/65/EU Annex II amending Annex (EU) 2015/863 and amending Annex (EU) 2017/2102	IEC 62321-4:2013+A1:2017 IEC 62321-5:2013 IEC 62321-6:2015 IEC 62321-7-1:2015 IEC 62321-7-2:2017 IEC 62321-8:2017

Signed for and on behalf of the manufacturer:

Name of manufacturer: TKO Technologies Pte Ltd
Address of manufacturer: 110 Lor 23 Geylang #02-01 Singapore 388410
Place of issue of declaration: Singapore
Date of issue of declaration: 20th November 2024

Signature:
Name: Daniel He
Appointment: CEO

TKO TECHNOLOGIES PTE. LTD.
110 Lor 23 Geylang #02-01 Singapore 388410
UEN: 202206220W

EU DECLARATION OF CONFORMITY

Products: MC-18

This declaration of conformity is issued under the sole responsibility of the manufacturer.

The objects of the declaration are in conformity with the following directives and harmonised standards:

Directives	Harmonised Standards
Electromagnetic Compatibility (EMC) 2014/30/EU	EN IEC 61000-6-3:2021 EN IEC 61000-3-2:2019+A1:2021 EN 61000-3-3:2013+A1:2019+A2:2021 EN IEC 61000-6-1:2019 EN 61000-4-2:2009, EN IEC 61000-4-3:2020, EN 61000-4-4:2012 EN 61000-4-5:2014+A1:2017, EN IEC 61000-4-6:2023 EN 61000-4-8:2010, EN IEC 61000-4-11:2020
Low Voltage (LV) 2014/35/EU	EN IEC 60335-1:2012+AC:2014+A11:2014+A13:2017+A1:2019 +A2:2019+A14:2019+A15:2021 EN IEC 60335-2-29:2021+A1:2021 EN IEC 62233:2008
RoHS 2011/65/EU Annex II amending Annex (EU) 2015/863 and amending Annex (EU) 2017/2102	IEC 62321-3-1:2013 IEC 62321-7-1:2015 IEC 62321-4:2013+A1:2017 IEC 62321-7-2:2017 IEC 62321-5:2013 IEC 62321-8:2017 IEC 62321-6:2015

Signed for and on behalf of the manufacturer:

Name of manufacturer: TKO Technologies Pte Ltd
Address of manufacturer: 110 Lor 23 Geylang #02-01 Singapore 388410
Place of issue of declaration: Singapore
Date of issue of declaration: 02nd December 2024

Signature:
Name: Daniel He
Appointment: CEO

KEY FEATURES

OBM

- Designed for one-man installation.
- As the lightest OBM in its class, the M-10 is the only 10kW OBM designed to be hand-carried. The custom-designed quick-release transom mount lets you leave the mount behind while detaching the OBM – resulting in the easiest mount-dismount process in the industry.

Folding tiller

- Flexibility and Control with Multi-position Tiller
- 3 tiller positions to fulfil your every need. Fold away the tiller to maximise deck space while idling, half-extend for low-speed manoeuvring, and fully extend for maximum leverage and control at high speeds.
- Safety button (fwd/reverse) – Experience precise control with the adjustable resistance throttle. Unlock high-power and reverse modes with a press of the integrated safety button.
- Single-lever Trim and Tilt.
- Trim by hand with the press of a lever. Adjust for any loads and sea conditions with trim angles from 0° to 30°.

IP67 Motor

72V FOC Controller

The M Drive controller sets a new standard for marine propulsion. Designed for peak performance and effortless reliability, it's built to handle the toughest conditions without compromise—delivering power, efficiency, and control when you need it most.

Compact and Efficient Design

Multilayer controller engineered to fit inside the motor housing, ensuring peak performance in demanding marine environments.

Optimized Thermal Management

Passive cooling system eliminates the need for fans or tubes, delivering reliable power even during sustained full-throttle use.

Intelligent Power Control

Integrated data connection with advanced FOC technology continuously adjusts for maximum range, power, and efficiency.

Custom SPC DC Motor

The M Drive motor development started with a custom-made stator assembly fully hand wound for maximum copper content with 99.9% pure copper windings before being fully potted and mated to an industry leading fine air gap SPM rotor.

Every rotor is then capped with a patented magnet retention cap before they are dynamically balanced on both ends of the rotor assembly for smooth vibration free operation.

The final part of the puzzle was to ensure a maintenance free seal for both the drive shaft and power / data cables used to connect the motor with the on-board trip computer and battery management system. Using multiple in-line shaft seals, custom patented cable seal designs and high tolerance shaft machining ensures not only a powerful lightweight design but also a highly reliable low maintenance motor for many years of use.

M Drive motor design has been optimised for hydrodynamic efficiency, allowing for minimal drag and efficient water flow to the propeller.

Single Cable Operation

- Our single cable connection with integrated power and data allows you to simply plug and play. The power connectors are never live unless both ends are connected.

GPS-enabled Trip Computer

- With a screen optimised for outdoor use and every function accessible from the display, get all the information you need in a single glance – no more fiddling around with complicated menus or apps out at sea.

INSTALLATION

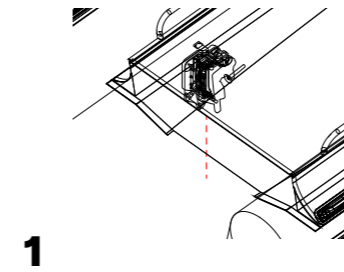

1

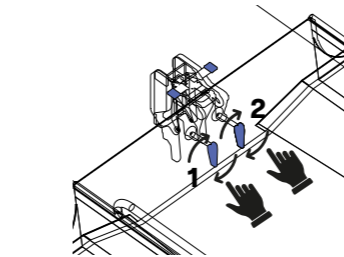

2

Installing the mount

In single outboard use applications, install the mount dead-centre to the transom of your boat as shown in the diagram above and secure the mount clamps to the transom with hand tightness.

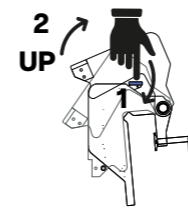

1

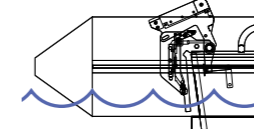

2

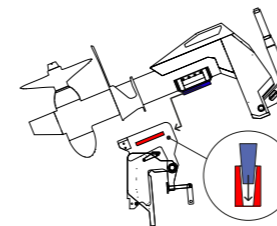

3

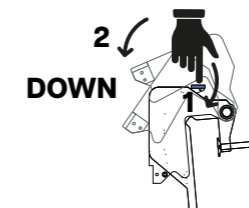

4

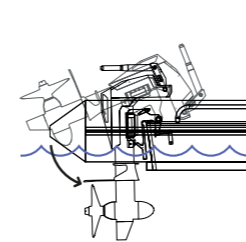

5

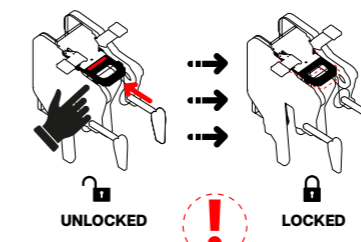

6 LOCK WHEN OBM IS INSTALLED!

Installing the outboard motor

Keep hands and fingers clear of moving parts when tilting the mount

- 1,2 - Press down on the trim lever to tilt the mount to the highest position to receive the outboard.
- 3 - With the outboard inside the boat, secure the outboard safety line to a fixed point in the boat before installing it. Aim the dovetail mount into the tapered receiver of the mount until you hear a positive click.
- 4,5 - Press down on the trim lever to lower the outboard into the water.
- 6 - Important! -Lock the outboard to the mount by pushing in the locking handle as shown in the diagram.

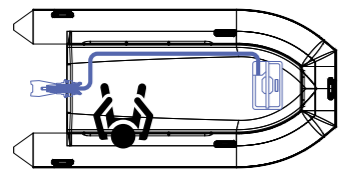

EXAMPLE 1

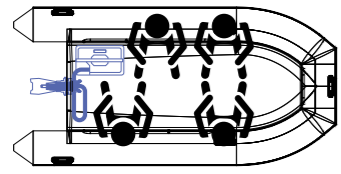

EXAMPLE 2

Before setting off

Boat Balance

Do position the battery in a sheltered, non-slip, position, secured to boat

Balance the boat by positioning the battery, passengers and other items on board the boat to achieve a suitable and safe boat trim.

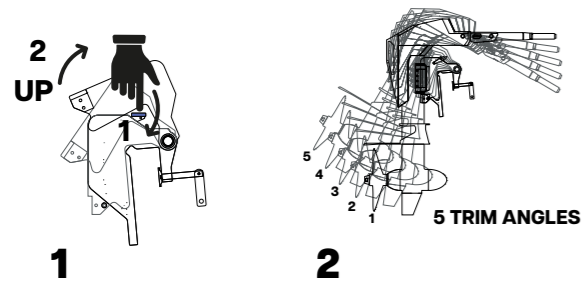

5 TRIM ANGLES

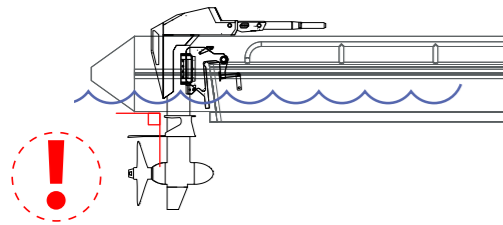

Trim Angle Adjustment

Stop the boat before making any trim adjustments to ensure safe handling

Check that the anti-vent plate is at or below the level of the boat keel

The outboard should be adjusted to one of the five different trim positions to suit the boat and running conditions, e.g. number of people in the boat, sea condition, boat type etc.

To trim the outboard, press down on the trim lever, then press down on the tiller to rotate the outboard.

Connecting the power cable

Check that the outboard is free to turn to hard port and starboard without any obstruction to the cable.

Do not use connectors that are wet or corroded

Use the OBM end cable clamp to lock the cable end securely to the OBM

1,2 - Connect the cable into the outboard first, then to the battery. Push the connector in until it is fully inserted.

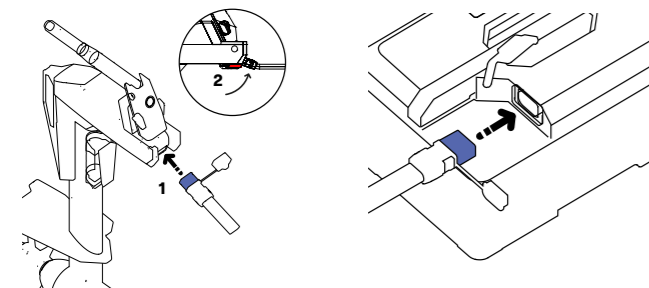

1 CONNECT OBM FIRST 2 CONNECT BATTERY AFTER

ENSURE THAT CONNECTORS ARE FULLY INSERTED

OPERATION

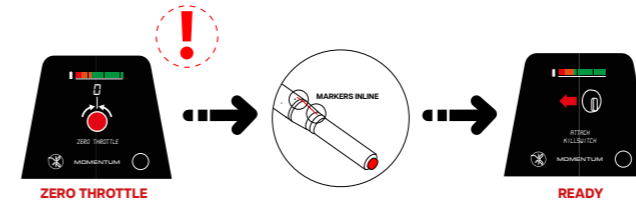
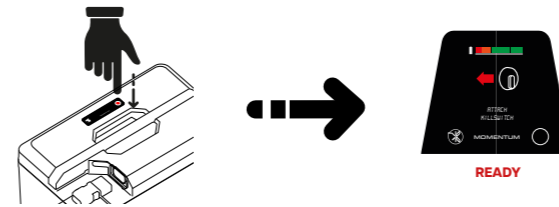

Powering the system

Always set the throttle to zero before powering the system.

Check that safety button can be depressed and springs back when released.

Press the on/off button on the battery until the battery display turns on. The display on the outboard will also turn on at the same time and will show the READY screen.

If the ZERO THROTTLE screen is shown, perform the following steps to zero the throttle.

Setting the throttle to zero

Loosen the throttle friction lock until the throttle springs back to zero. The return should happen automatically and the markers on the throttle will be aligned.

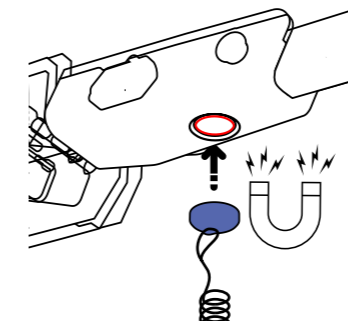

Attaching the killswitch

Secure the killswitch leash to your wrist or life jacket.

Once ready to make way, attach the killswitch to the red ring below the mid-tiller.

The screen will switch from the READY screen to the LIVE screen.

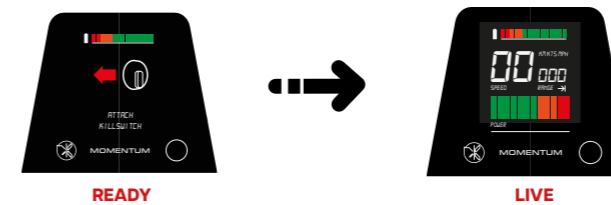

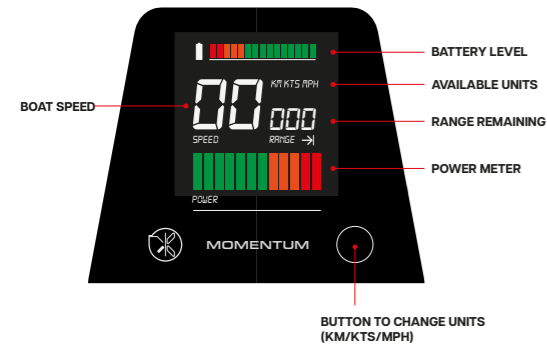

Your outboard motor screen

The display screen is grouped into 4 parts:

- Battery level remaining
- Boat speed
- Range remaining
- Power/throttle level

The units for the boat speed and range remaining can be changed by tapping the bottom right button (KM/KTS/MPH)

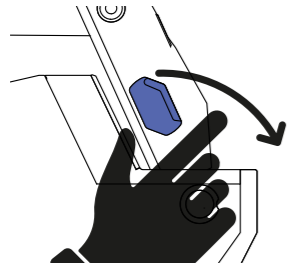

Deploying the in-built tiller

Twist the knob on the mid-tiller to unlock the tiller and adjust to preferred angle. The tiller locks at 2 positions.

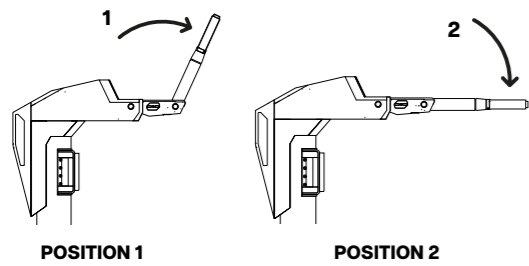

Using the throttle

The throttle can be freely rotated forward until half throttle.

In order to rotate further forward, the safety button has to be depressed to allow rotation to full throttle.

To rotate the throttle in reverse, first depress the safety button.

The safety button prevents accidental full-power forward and reverse engagement.

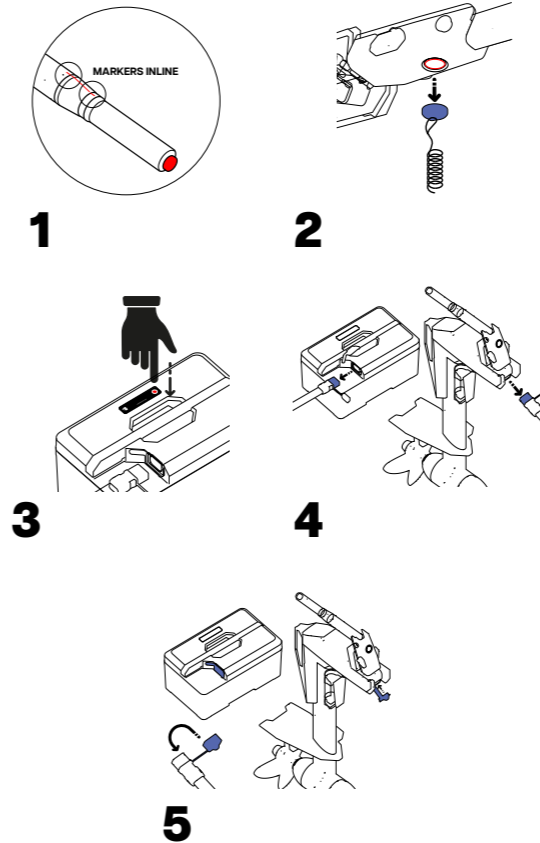
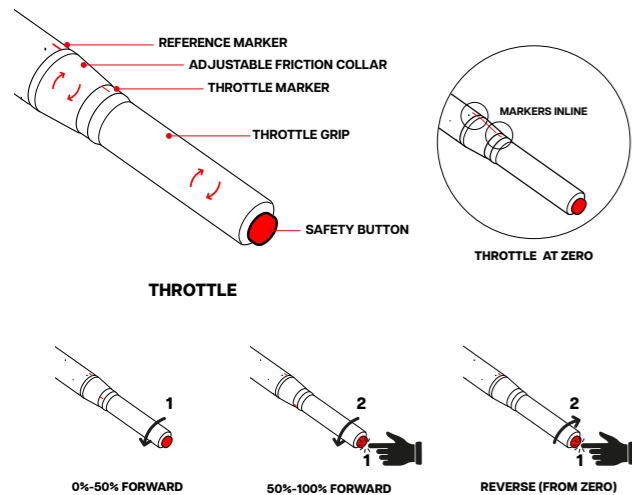

Turning off the outboard

- 1 - Return throttle to zero/neutral position
- 2 - Remove kill switch
- 3 - Press power button on battery until the battery display turns off
- 4 - Disconnect the cable from the battery and outboard
- 5 - Fit the weather caps back over the outboard and battery connectors.

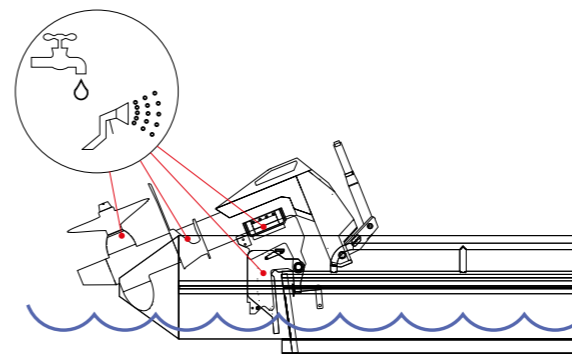

After using the outboard

Outboard

If the outboard is to be left on the boat, tilt it to the highest position to keep it out of the water, and rinse down the underwater parts with freshwater. This is to minimise marine fouling due to extended immersion in fresh or sea water. Cover the top of the outboard with a weather-proof cover.

If the outboard is removed from the boat, rinse down the underwater parts with fresh water and allow to dry before storage or transportation.

ON BOAT - KEEP OUT OF WATER

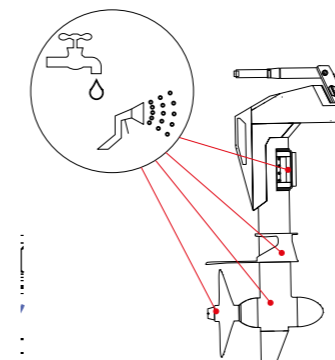

OFF BOAT

Battery

Wipe battery with a dry clean cloth before charging or storage

PRE-SEA CHECK

Charging & Storage

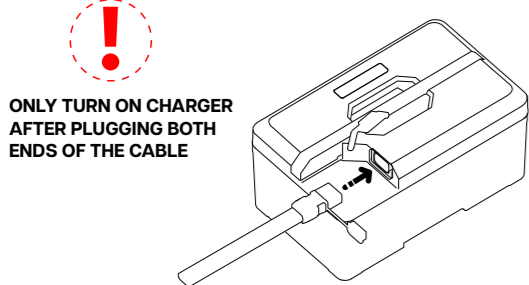

Charging the battery - connect the charger to the battery BEFORE turning on the charger

Do not connect the charger to a wet battery.

Store the battery and OBM under dry shelter and within an optimal temperature range of 15-30 °C

If storing the battery for more than 3 months, always store the battery fully charged and do not let the state of charge drop below 50%.



- Throttle can rotate freely and springs return to zero, Safety button can be pressed and released freely
- Tiller is free to rotate and can be locked in position
- Steering is unobstructed and not loose
- Propeller not damaged and securely fastened to OBM with cotter pin, nut and anode
- Transom mount securely seated on transom, both clamps are securely fastened and trim/tilt levers can be pressed and released freely
- OBM, Battery and Power/Data cable connectors are dry before connection
- Kill switch secured to provided lanyard
- Note the following high risk situations:

Situation	Risk	Solution
Operating in shallow or rocky waters	OBM may strike the seabed or underwater objects	Trim OBM up and proceed at a slow speed
Beaching	OBM may strike the seabed or underwater objects	Trim OBM up and proceed at a slow speed
Low battery level	Insufficient battery capacity to return	Operate at a lower speed to maximise range

MAINTENANCE & INSPECTION

MAINTENANCE SCHEDULE

Maintenance Task	Maintenance Action	Maintenance Interval
Inspect propeller pin and nut for looseness	Replace missing pin and/or tighten nut	Before each use
Inspect propeller blades and hub for damage	Replace damaged propeller	Before each use
Inspect battery case for damage	Replace damaged battery	Before each use
Inspect connectors for corrosion	Replace damaged connectors	Before each use
Inspect three anodes (propeller, motor, transom mount)	Replace anodes if required	Every 3 months
Grease contact points on transom mount	Apply marine grease to dovetail, latch, clamp	Every 3 months
Inspect transom mount and OBM for loose screws	Tighten loose screws with suitable thread lock / anti-corrosive compound	Every 6 months
Inspect transom mount entry guide for cracks	Replace damaged parts	Every 6 months
Recommended yearly inspection	Bring OBM to dealer for recommended yearly inspection (seals, O-rings, connectors)	Every 12 months

REPLACEMENT PROCEDURES

Tools & parts required

Standard metric hand tools and electrical equipment are required for the tasks. For example:

- allen key wrench set
- socket wrench set
- needle nose pliers

Consumables required are:

- Tefgel anti-corrosion/anti-seize
- Loctite 243
- Loctite 425 (suitable for use with plastics)
- marine grease

PROPELLER

- 1.1 remove split pin
- 1.2 loosen prop nut
- 1.3 remove propeller anode (MA002) and propeller hub cap (MA004)
- 1.4 slide old propeller off propeller shaft
- 1.5 slide new propeller onto propeller shaft
- 1.6 replace propeller hub and propeller anode (use new anode if necessary)
- 1.7 align slot on propeller hub with split pin hole on propeller shaft and tighten prop nut
- 1.8 install new split pin

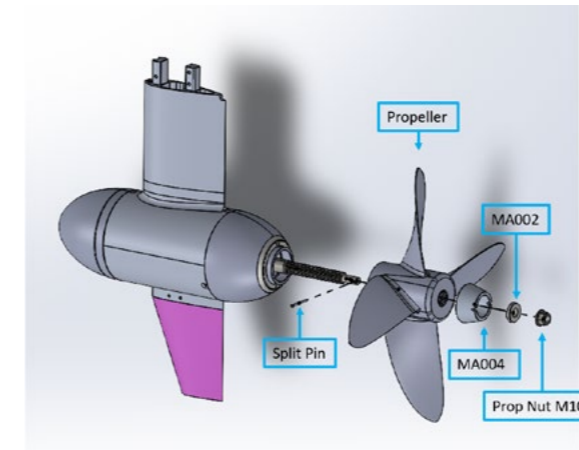

PROPELLER ANODE REPLACEMENT

- 2.1 to remove anode, repeat steps (1.1) thru (1.23)
- 2.2 to install anode, repeat steps (1.6) thru (1.8)

MOTOR ANODE REPLACEMENT

- 3.1 remove the propeller as per a))
- 3.2 remove two screws
- 3.3 remove motor anode, use a flat head screwdriver to lightly tap to loosen the anode, if necessary
- 3.4 install new motor anode
- 3.5 apply Tefgel on each screw before installing screws

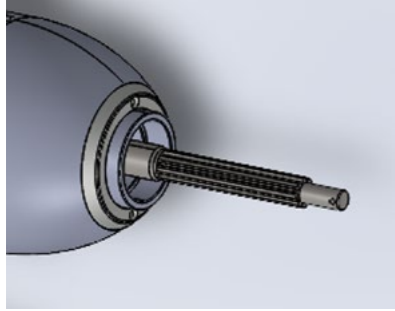

ANTI-GROUNDING SKEG REPLACEMENT

- 4.1 loosen two set screws
- 4.2 remove old skeg
- 4.3 install new skeg (MA005)
- 4.4 apply Tefgel on each screw before installing screw

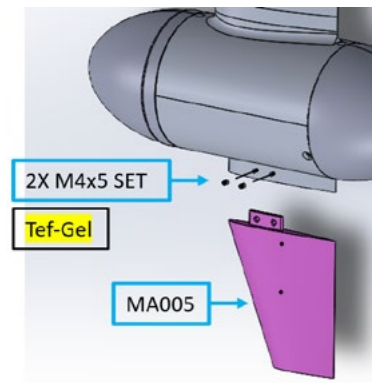

TRANSOM MOUNT

- 5.1 anode replacement
- 5.2 remove two cap screws
- 5.3 remove both anodes (TM066)
- 5.4 fit new anodes and tighten screws
- 5.5 apply Tefgel before installing cap screws

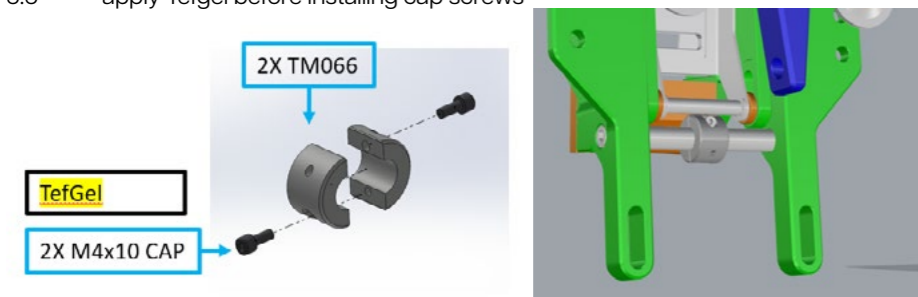

THROTTLE GRIP

- 6.1 loosen screw and slide grip off throttle
- 6.2 slide new grip onto throttle
- 6.3 align zero throttle marks
- 6.4 tighten screw to ensure grip does not slip over throttle

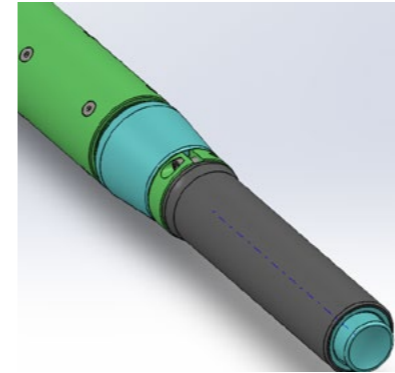

TRANSOM MOUNT ENTRY GUIDE

- 7.1 mounting block/entry guide replacement
- 7.2 to remove the CSK screws to remove the mount (TM049)/entry guides (TM047)
- 7.3 fit the new mount/entry guides and tighten screws
- 7.4 apply Loctite 425 before installing CSK screws

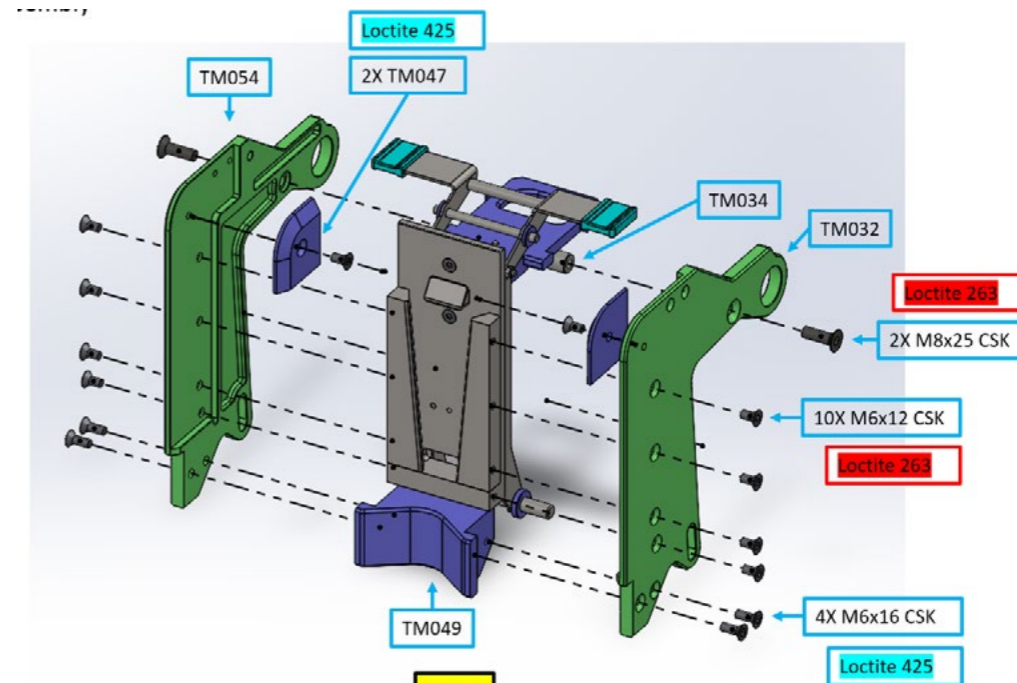



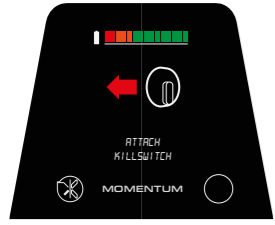
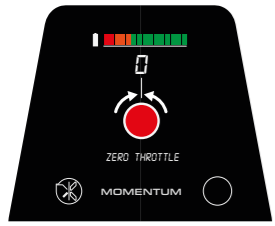
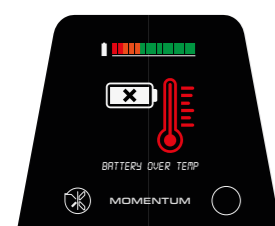
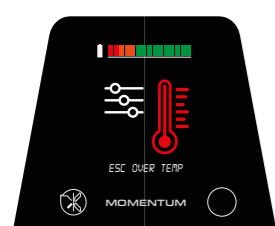

TROUBLESHOOTING

A fault/warning message(s) will appear on the display in the event of an outboard/battery fault or warning.

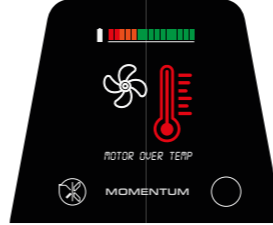
Return the throttle to zero and remove the killswitch before referring to the following table for details and solutions. The outboard will shut down when the temperature of the motor or battery exceeds the limits or the battery voltage drops too low during operation.

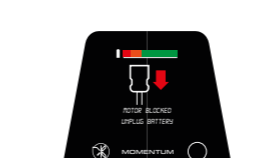
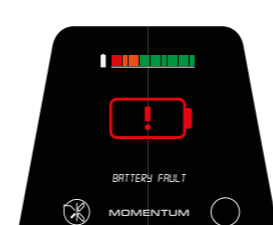
Warning / Fault Message	Likely Cause	Solution
	Killswitch is not placed on tiller or remote throttle	<ul style="list-style-type: none"> Attach killswitch on tiller or remote throttle
	Throttle has been turned to or held in forward/reverse direction	<ul style="list-style-type: none"> Take hand off throttle or loosen throttle friction ring
	Battery cells or BMS temperature has exceeded limit	<ul style="list-style-type: none"> Stop use of battery Inspect for physical damage or deformation Ensure that battery is in a well-ventilated area and ambient temperatures are between the recommended values Contact your dealer for support
	Electronic Speed Controller (ESC) temperature has exceeded limit	<ul style="list-style-type: none"> Stop use of motor Ensure that front end of the motor is free from obstruction and fully immersed in the water Wait for message to disappear after ESC has cooled down If message reappears after resuming operation, contact your dealer

	Motor temperature has exceeded limit	<ul style="list-style-type: none"> Stop use of motor Ensure that mid-section of the motor is free from obstruction and fully immersed in the water Check that boat is not overloaded or underpowered Wait for message to disappear after motor has cooled down If message reappears after resuming operation, contact your dealer
  	Motor torque demand has exceeded limit	<ul style="list-style-type: none"> Ensure that outboard is safe to handle Remove killswitch Turn off the battery, then disconnect battery from outboard motor Raise outboard to maximum angle Inspect propeller and shaft for entanglement with rope/fishing net/sea weed/etc. Check that propeller can be rotated freely by hand before resuming operation
	Battery fault, excluding high temperature	<ul style="list-style-type: none"> Stop use of battery Inspect for physical damage or deformation Contact your dealer for support
	Battery level < 20%	<ul style="list-style-type: none"> Review voyage plan and return to home or operate at reduced speed in a safe manner

WARRANTY

The limited warranty of the M-Series outboard motor covers 1 year (commercial use) and 2 years (private use) from the date of delivery.

OPERATING FAULT TABLE

Description of Observation	Likely Cause	Solution
Propeller sucks air from the water surface (ventilation)	OBM is trimmed up too much / OBM shaft length is not long enough	Trim OBM down / Check if anti-ventilation plate is at least at or below the level of the boat keel
Propeller cavitates, particularly when operating on a large/heavy boat	Insufficient thrust from the standard propeller	Replace standard propeller with high thrust propeller
Tiller pulls to one side more than the other	OBM is trimmed down too much	Trim OBM up
Excessive vibrations	Entanglement with seaweed/plastic bag etc. Loose or damaged propeller Loose transom mount Loose anti-ventilation plate	Stop the boat in a safe location, put the throttle to zero, remove the kill switch and tilt the OBM up to check the propeller/transom mount/anti-ventilation plate. Take necessary remedial action.
No GPS speed display	GPS unit requires more time to acquire satellite fix	Wait for up to 5 minutes from first power on before moving off / more time may be required if boat is moving.
OBM display does not light up	Connector is not engaged fully	Check that connectors on OBM and battery are fully pushed in.
No throttle response	Kill switch is not on Throttle not at zero on first power on.	Zero throttle then put on kill switch.
Battery LED does not light up	Battery power button not depressed long enough	Press battery power button for about 5 seconds.
Battery cannot be turned off	Battery power button not depressed long enough	Press battery power button for about 10 seconds.

USER NOTES

